

**ZT100 WATER IN OIL MONITOR**  
**INSTALLATION / OPERATION MANUAL**

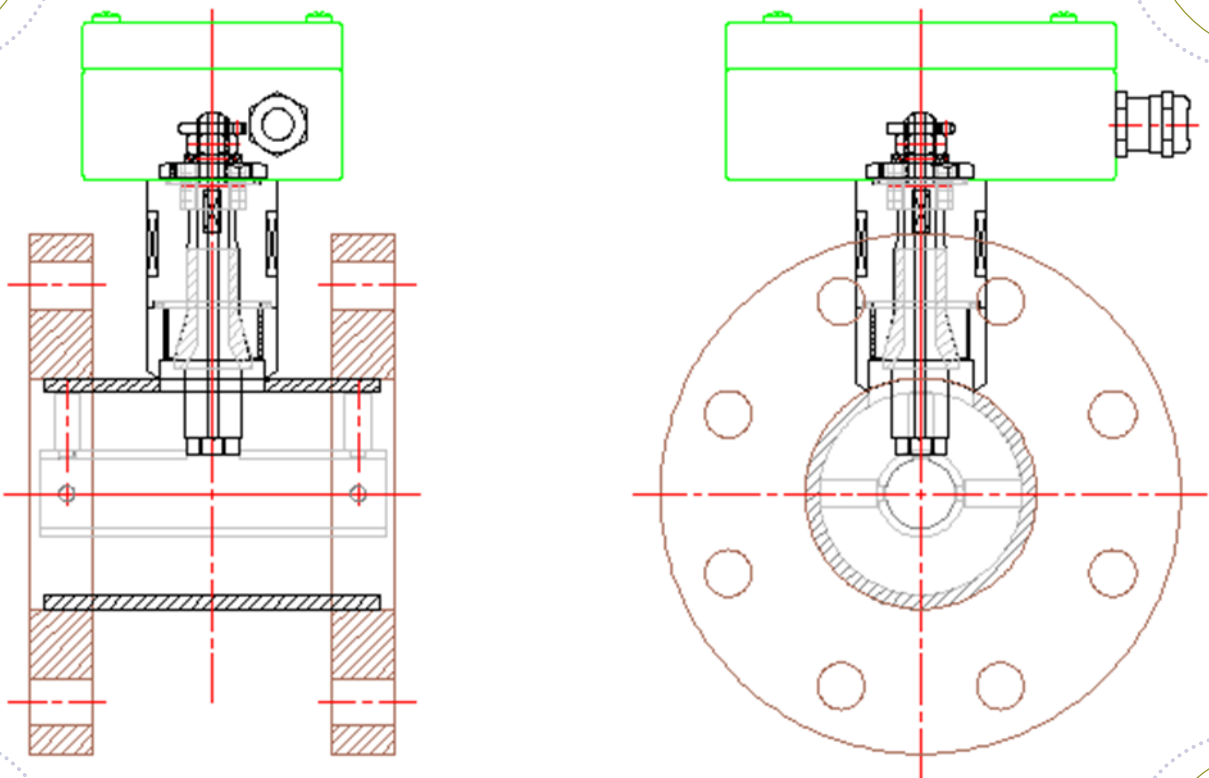

# TABLE OF CONTENT

## INDEX

---

Overview	3
Mechanical Connection	4
Electrical : 4-20mA, RS-232	5
Field Calibration - Zero Offset	6
Field Calibration - Temp compensation	7
RS-232 Protocol	8
HART Protocol	9
HART : Universal Commands (Rev 6)	10
HART : Device Specific Commands	11-12

---

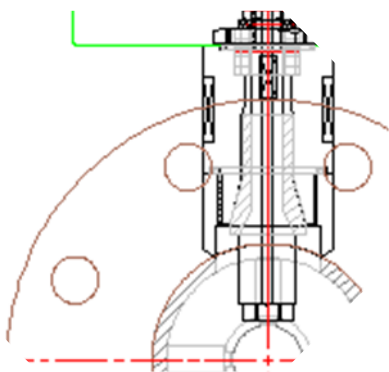

# OVERVIEW

ZelenTec ZT100 is an inline device capable of determining the amount of water in a stream of oil.

The device is loop powered and provides a 4-20mA signal proportional to the water content.

The dielectric properties of Oil and Water are vastly different and the ZelenTech ZT100 is able to determine the ratio by measuring the capacitance of the passing stream. The ZT100 constantly measures the temperature and compensates for capacitance changes that are due to temperature fluctuations.

ZT100 is available in Standard Version capable of 0-25% of water as well as in High Range versions capable of 0-100% water.

The Dielectric Constant (DC) varies from oil to oil and is mainly a function of the Specific Gravity (SG). The ZT100 will measure any oil with a DC in the range of 1.7 to 2.3 without a need for any additional tweaking. This covers all normal fuels, lubrication and hydraulic oils as well as crude oils. The ZT100 will also work fine with most vegetable oils and biofuels. A simple calibration procedure will get the ZT100 ready for your oil. In most cases a single press of a button will do.

---

## Dielectric Constant:

The dielectric constant is the ratio of the permittivity of a substance to the permittivity of free space. It is an expression of the extent to which a material concentrates electric flux, and is the electrical equivalent of relative magnetic permeability.

---

---

## Installation Tips:

- \* Avoid flow going downwards
  - \* Avoid open ended pipes. A small amount of backpressure is required.
  - \* Do not install on suction side of a pump.
  - \* Ensure the pipe is full.
  - \* Mixing may be required for high water ratios.
- 

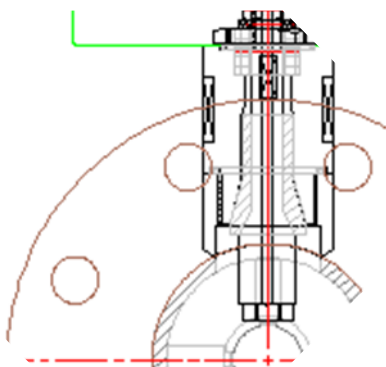

# MECHANICAL CONNECTION

The ZelenTech ZT100 Water In Oil monitor is available in many different sizes and can be built from a range of materials suitable for different liquids, temperatures, environments and pressures.

Always ensure that your model is suitable for the liquid, temperature and pressure that can be expected in the system where you install your monitor. **Pressurised equipment can cause serious damage.** Always follow correct standards and regulations. If unsure contact ZelenTech for assistance.

For flanged connections make sure you use a suitable gasket and only mate with a flange of same type and pressure rating. Verify that bolts used are of correct size, length and material.

For threaded connections make sure the mating side thread is of the same type as the monitor.

## Flanged Pipe Joints

**Standards:** ANSI, DIN, JIS or SAE flanges.

**Pressure Ratings:** Up to Class 900 (PN150)

### Available Sizes for ZT100:

Small:

- \* NPS (inch) 1, 1¼, 1½, 2, 2½, 3
- \* DN (mm) 25, 32, 40, 50, 65, 80

Medium:

- \* NPS 4, 5, 6, 8, 10, 12
- \* DN 100, 125, 150, 200, 250, 300

Large:

- \* NPS 14, 16, 18, 20, 22, 24, 26, 28, 30, 32
- \* DN 350, 400, 450, 500, 550, 600, 650, 700, 750, 800

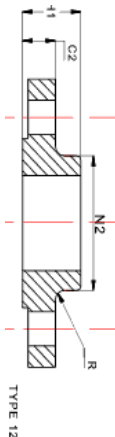

## Threaded Pipe Joints

### NPT, BSPT

- \* Jointing Threads (Tapered)
- \* Requires thread tape or thread sealant
- \* Male thread is always tapered.
- \* Female thread can be tapered or parallel/straight

### BSP

- \* Longscrew Threads (Parallel)
- \* Requires O-Ring or Washer Seal

### Available Threaded Sizes for ZT100:

- \* NPS 1, 1¼, 1½, 2, 2½, 3
- \* DN 25, 32, 40, 50, 65, 80

For larger sizes always use Flange.

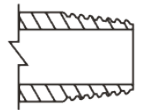

# ELECTRICAL : 4-20mA, RS-232

## Power Supply - 4-20mA Current Loop

The ZelenTech ZT100 Water In Oil provides an Analog Signal 4-20mA proportional to measured water content. The Current Loop has to be powered externally and will provide enough power for the ZT100 to operate. The ZT100 will operate from 12 to 26VDC.

## Power requirements

Maximum ripple (47 to 125 Hz) 0.2 V p-p  
Maximum noise (500 Hz to 10 kHz) 1.2 mV rms  
Maximum series impedance (500 Hz to 10 kHz) 10  $\Omega$

Power for a two-wire instrument loop is typically 24VDC. As always, the voltage must be sufficient to provide the necessary lift-off voltage for the field device. Take into account voltage drops in the cable and load resistor, as well as from any passive intrinsic safety, or IS, barrier present. Smart devices may take up to 22 mA to indicate an alarm condition. Use this value to calculate the worst loop voltage drop

## Cable considerations

If possible, use individually shielded twisted pair cable. Unshielded cables may be used for short distances, provided ambient noise and cross-talk will not adversely impact communication. The minimum conductor size is 0.51mm diameter (#24 AWG) for cable runs less than 1,500 meters (@ 5,000 ft.) and 0.81mm diameter (#20 AWG) for longer distances.

Shield shall be grounded in ONE end only to avoid earth loops.

**CAUTION!**  
**The Current Loop MUST be floating!**  
**Grounded or badly isolated loop WILL cause damage to**  
**the ZT100 electronics!**

## RS-232 Interface

The ZelenTech ZT100 Water In Oil is fitted with a RS-232 terminal interface. The interface is accessible using the supplied RS-232 cable only. Connect the cable to terminal J7 on the PCB. Connect the other end to a PC with RS-232 interface, or as many PCs today lack RS-232, use a USB-RS-232 Converter. The supplied RS-232 cable has a small PCB in the black RS-232 Connector and communication will not work with any other cable.

## Terminal Software

There are many alternatives available.

PUTTY.EXE is a free open source terminal software that can easily be found for free download.

## Connector J1 Current Loop

Voltage: 12 to 28VDC (Floating / Isolated)

Power Consumption: Max 22mA

Pin 1: (+)

Pin 2: (-)

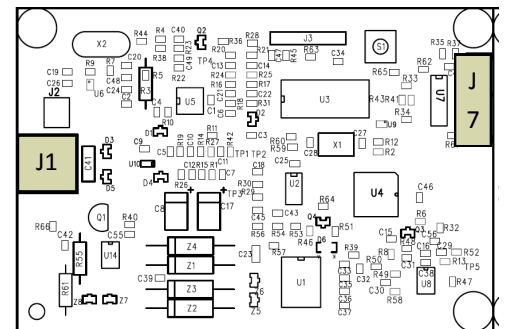
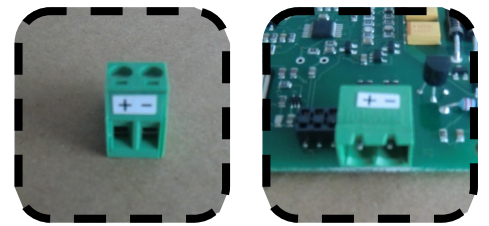

## Connector J7—RS-232

5 pin 0.1" pitch header connector.

Use with supplied RS-232 cable ONLY.

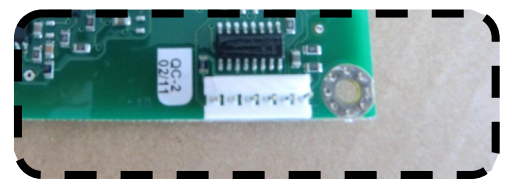

## RS-232 Communication Settings

Bits per second: 9600  
Data bits: 8  
Parity: None  
Stop Bits: 1  
Flow Control: None



# FIELD CALIBRATION - ZERO OFFSET

## Field Calibration Overview

Field calibration is the process of teaching the ZT100 Water In Oil Monitor what level of capacitance corresponds to given level of water content. This is a single point offset, the electronics will take care of the rest. This teaching process is referred to as **Zero Offset**. The process can be performed at any water content, the software will automatically calculate the zero point from any given water content.

For applications with large temperature fluctuations optionally the ZT100 can be taught how to compensate for temperature inflicted changes in capacitance. Temperature is compensated for using a **Temperature Compensation Factor**.

## Zero Offset using S1 button

Pressing the S1 button located on the PCB inside the unit will instantly zero the unit to the liquid inside the unit and use the current temperature as the point of origin for temperature compensation. It will assume the oil is dry (0%). The Zero level can if needed be modified using the command **cal** should a lab result be available at a later point in time.

## Zero Offset using RS-232 Interface

This is a 2 step process using 2 different commands.

Command **save** will save the current capacitance and temperature reading to memory.

Command **cal #.##** (#.## being known or estimated water content) will offset the internal reference table to match given water content using the values saved with command **save**.

It is quite possible to enter an estimate for **cal** directly after having performed the **save** command. This estimate can be corrected at a later time should a lab result or better estimate be available later on. Note: Do not **save** again as this will overwrite the saved reference points that you have water content data for.

## Zero Offset using HART Interface

Performed exactly as the RS-232 process.

**save** command is represented by HART Command #144

**cal** command is represented by HART Command #143

See Device Specific HART Commands for byte format.

## Zero Offset

Zero Offset can be performed using 3 different methods:

- 1) S1 button located inside the unit.
- 2) Using the RS-232 Terminal Interface.
- 3) Using the HART Interface.

## RS-232 Terminal

Zero Offset commands

**save[enter]**

**cal 0[enter]**

*The above commands will save the current readings and tell the unit that current water content is 0%. Water content level can be tweaked to match lab results later.*

**cal 0.25[enter]**

*This will tell the unit that the water content (at time of save) was 0.25%.*

## Calibration samples

Take sample as close in time as possible to the time of issuing the **save** command.

Take sample from a location close to the ZT100 Monitor.

Ensure your sample is representative.

Allow sample line/points to drain out old stuck content allowing you a fresh sample.

# FIELD CALIBRATION - TEMP COMPENSATION

## Temperature Compensation

The temperature coefficient (**tc**) is the relationship between temperature and capacitance. The coefficient is applied to the measured capacitance per degree Celsius of temperature change and pivots around the temperature saved using the **save** command.

### Find the tc

Record T1 and C1 as temperature and capacitance while running at a lower temperature. Record T2 and C2 as temperature and capacitance while running at an elevated temperature.

Calculate tc using the formula on the right.

### Apply the TC

The temperature compensation coefficient is entered into the ZT100 using the RS232 or HART interface.

## Temperature Coefficient Formula

$$1 - \frac{\left( \frac{C2 - C1}{T2 - T1} \right)}{C1}$$

## RS-232 Terminal / HART

The RS-232 command for setting the temperature coefficient is **tec #.####**. (#.### being the TC)

Command #142 is used to set tc using HART. See HART Command reference for byte format.

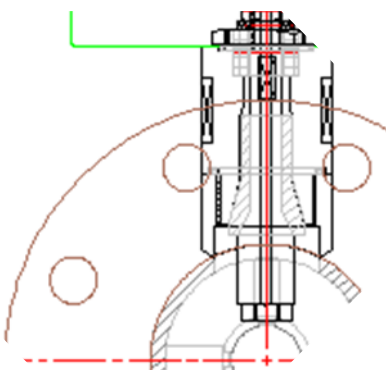

# RS-232 PROTOCOL

Command	Action	Terminal Output Example
show	Provides a terminal output of the latest reading	Capacitance 270.1pF Per cent H2O: 13.6% Temperature: 21.7C
param	Printout of current parameters	Calibrated to: 0.0% H2O Range: 3% Tempco:1.0000 Alarm level: high
table	Printout of the Lookup Table showing the relationship between probe capacitance and the water content.	a. Capacitance: 179.8pF H2O: 0% b. Capacitance: 185.3pF H2O: 1% c. Capacitance: 190.9pF H2O: 2% ...
reset	Reset the lookup table to Factory Default	
alarm	Set current loop alarm level for out of range values. Can be either high or low, where low is 3.8mA and high is 20.2mA, e.g. In parameters: low or high. Default is high.	alarm high
tec	Temperature Coefficient Factor. Allows values between 0.5 and 2, maximum 4 decimals	tec 1.0007
save	This command will tell EASZ-1 to save its latest capacitance and temperature measurement as a calibration reference value to be used with the cal command.  Manual storage of pF or temp value is possible., see example.	save save pf 199.9 save t 75.5
avg	Sets the number of measurements over which reading is averaged. In effect a damping.  Max: 20 Default 20 Min: 1	average 10
cal	Sets the percentage value used after cal to match the pF value stored using store.  The internal calibration table will be offset using the value saved with command save. Accepts 2 decimals.  The S1 button on the PCB performs command save followed by cal 0 and therefore allows zeroing to dry oil without computer.	cal 0.00
brdcst	Broadcast readings continuously over RS-232. at whatever rate is set by command average. Stop broadcasting by pressing q [enter]  capacitance (pF) , water content (%) , temp (°c)	
scal	This command will scale the 4-20mA output to desired range.  Max 25 for Low Range units, max 100 for High Range units.	scale 10[enter]

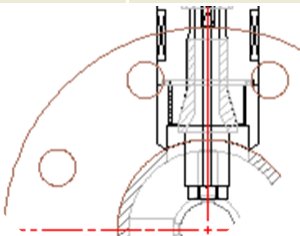

# HART PROTOCOL

DD	device description	MSB	most significant bit	SV	secondary (2nd) variable
FSK	frequency shift keying	PDU	protocol unit data	TV	tertiary (3rd) variable
HCF	HART Communication Foundation	PLC	programmable logic controller	QV	quaternary (4th) variable
LSB	least significant bit	PV	primary (1st) variable		

## HART – Introduction

ZelenTech ZT100 complies with HART protocol revision 6. This document specifies all device specific features and documents HART protocol implementation.

## HART Communication - Basics

HART (Highway Addressable Remote Transducer) is a digital protocol for field communication. It is widely accepted as a standard for digitally enhanced 4-20 mA communication with smart and microprocessor based field devices.

HART is a digital master/slave protocol. Slaves only send information when requested to do so by a master. The digital signal is superimposed onto the analog current loop without affecting it. The serial digital data channel is used to configure the device as well as allowing access to multiple process variables. To superimpose the digital signal with the current loop, a frequency shift keying (FSK) technique, based on the Bell 202 communication standard is used. Two frequencies, 1200 Hz and 2200 Hz are used to represent binary 1 and 0. Thus, HART communication is limited to 1200 Baud.

HART provides two different masters (primary and secondary) to each loop. Primary masters are typically PLCs, computer based controllers or monitoring systems. Secondary masters

are for example handheld communicators. Both masters can be connected to one current loop without disturbing the communication.

HART devices can operate in one of two network configurations:

- \* point-to-point
- \* multidrop connection

In case of a point-to-point connection, the 4-20 mA signal is used to communicate one process variable, while other process variables or configuration data are transferred digitally.

For multidrop mode the 4-20mA is locked at 4mA and all data is transferred digitally over HART.

## HART Setup

Poll address can be reset to 0 by keeping button S1 pressed during power up.



**HART**  
COMMUNICATION FOUNDATION

# HART : UNIVERSAL COMMANDS (REV 6)

The following universal commands are implemented. Please refer to your HART documentation for extensive information on each of these commands.

Command 0:	Read unique identifier.
Command 1:	Read primary variable.
Command 2:	Read loop current and percent of range.
Command 3:	Read dynamic values and loop current.
Command 6:	Write polling address and set/reset multi-drop mode.
Command 7:	Read loop configuration.
Command 11:	Read unique identifier associated with tag.
Command 12:	Read message.
Command 13:	Read tag, descriptor and date.
Command 14:	Read primary variable transducer information.
Command 15:	Read device information.
Command 16:	Read final assembly number.
Command 17:	Write message.
Command 18:	Write tag, descriptor and date.
Command 19:	Write final assembly number.
Command 20:	Read long tag.
Command 22:	Write long tag.
Command 34:	Write primary variable damping factor.
Command 35:	Write primary variable range values.
Command 38:	Reset configuration changed flag.
Command 40:	Enter/exit fixed current mode.
Command 42:	Perform device reset.
Command 43:	Set primary variable 0.
Command 45:	Trim loop current zero.
Command 46:	Trim loop current gain.
Command 48:	Read additional device status.
Command 56:	Write device variable transducer serial number.
Command 59:	Write number of response preambles.

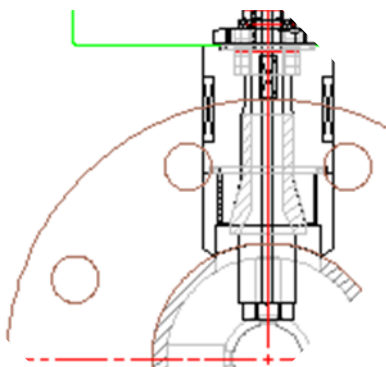

## HART : DEVICE SPECIFIC COMMANDS

Command 141	Load the capacitance/ H2O table with the default values.	Request Data Bytes:	none
		Response Data Bytes:	none
		Response Codes:	0x0 Success
Command 142	Set temperature coefficient.	Request Data Bytes:	0-3, float
		Response Data Bytes:	0-3, float
		Response Codes:	0x0 Success 0x3 Parameter Too Large 0x4 Parameter Too Small 0x8 Warning, set to nearest value
Command 143	Calibrate to entered percentage of water.	Request Data Bytes:	0-3, float
		Response Data Bytes:	0-3, float
		Response Codes:	0x0 Success 0x3 Parameter Too Large 0x4 Parameter Too Small 0x8 Warning, set to nearest value 0x72 Capacitance Not Set 0x73 Temperature Not Set
Command 144	Store current value of capacitance and temp. Return values to master.	Request Data Bytes:	none
		Response Data Bytes:	0-3, float (capacitance) 4-7, float (temperature).
		Response Codes:	0x0 Success
Command 145	Store an entered value of capacitance to use for future calibration.	Request Data Bytes:	0-3, float
		Response Data Bytes:	0-3, float
		Response Codes:	0x0 Success 0x3 Parameter Too Large 0x4 Parameter Too Small 0x8 Warning, set to nearest value
Command 146	Store an entered value of temperature to use for future calibration AND for reference when calculating temperature drift.	Request Data Bytes:	0-3, float
		Response Data Bytes:	0-3, float
		Response Codes:	0x0 Success 0x3 Parameter Too Large 0x4 Parameter Too Small 0x8 Warning, set to nearest value

# HART : DEVICE SPECIFIC COMMANDS

Command 147	Read H2O calibration value, temperature coefficient and reference temperature.	Request Data Bytes: Response Data Bytes: Response Code:	none 0-3, float (H2O calibration value) 4-7, float (temperature coefficient) 8-11, float (calibration temperature) 0x0 Success
Command 148	Read the table of Capacitance and %H2O	Request Data Bytes: Response Data Bytes: Response Code:	none 0-50, 3*17 bytes Table of 17 rows of 3 bytes 2byte unsigned int = Capacitance 1 unsigned char = Water Content (%) 0x0 Success
Command 149	Write a complete cap/H2O table to the card.	Request Data Bytes: Response Data Bytes: Response Code:	0-50, 3 byte X 17 entries 0-1 : unsigned int = Capacitance 2: unsigned char = Water Content (%) 0-50, 3 byte X 17 entries 0-1 : unsigned int = Capacitance 2: unsigned char = Water Content (%) 0x0 Success
Command 150	Change single row in cap/H2O table.	Request Data Bytes: Request Data Bytes: Response Code:	0-4 0: unsigned char = Table position 1-2 : unsigned int = Capacitance 3: unsigned char = Water Content (%) 0-4 0: unsigned char = Table position 1-2 : unsigned int = Capacitance 3: unsigned char = Water Content (%) 0x0 Success 0x02 Invalid selection 0x3 Parameter Too Large 0x4 Parameter Too Small