

ENRAF TANK FARM

GATEWAY CIU 888

The next generation CIU for reliable, accurate gauge and inventory data



Honeywell

GLOBAL EXPERIENCE. LOCALLY APPLIED.

Honeywell's Enraf Tank Farm Gateway CIU 888 is the critical link between tank gauging equipment and control room systems. It provides the operator with reliable, accurate, real-time tank inventory data 24 hours a day, 7 days a week. Replacing the legacy 858 and 880 series, the CIU 888 serves as the data acquisition unit for tank measurement equipment, continuously scanning gauge data. It is used to calculate accurate tank inventory data according to international standardized calculation methods, such as the API, ASTM, GPA and many others.

All measured and calculated data is directly available for use by host applications such as the inventory management system, the DCS or management information system via multiple dedicated serial host links and network interfaces. Support of multiple protocols guarantees simple and reliable connectivity of installed field equipment to the control room. The modular design provides a flexible upgrade path for the future.

ENHANCED CONNECTIVITY

The CIU 888 (pronounce as "triple eight") series is the first fully Ethernet enabled CIU available in the market. While previous generations of tank interface units have been based mostly on serial interfaces, the CIU 888 offers connectivity via multiple Ethernet ports. Internal firewalls enable safe and secure connections with multiple systems simultaneously, control systems and Office LAN cannot interfere due to strict segregation. A dedicated service LAN port on the front provide technicians easy access to configure the unit locally and to communicate with the field equipment.

Also here the layered security model (LCSM), with user and access profiles, helps to promote safety and security.

The CIU 888 robustness is based on strict industrial design rules. All boards are tropicalized (acc. ISA 71.04), and the CAE thermal design using heat-pipes instead of conventional fans results in a full ruggedized, all-solid-state, non-moving parts solution, built to last. Unique redundancy features will ensure uninterrupted data availability to all users. Redundant Ethernet ports complete the redundancy concept, simplifies implementation further reducing costs and ensure uninterrupted availability of data.

An easy-to-read colour display at the front provides diagnostic information, easy to interpret, supporting faster service. The graphic diagnostic dashboard combined with a ring of light (a color-coded LED ring surrounding the key pad) provides an at-a-glance and unambiguous indicator of system health and availability.

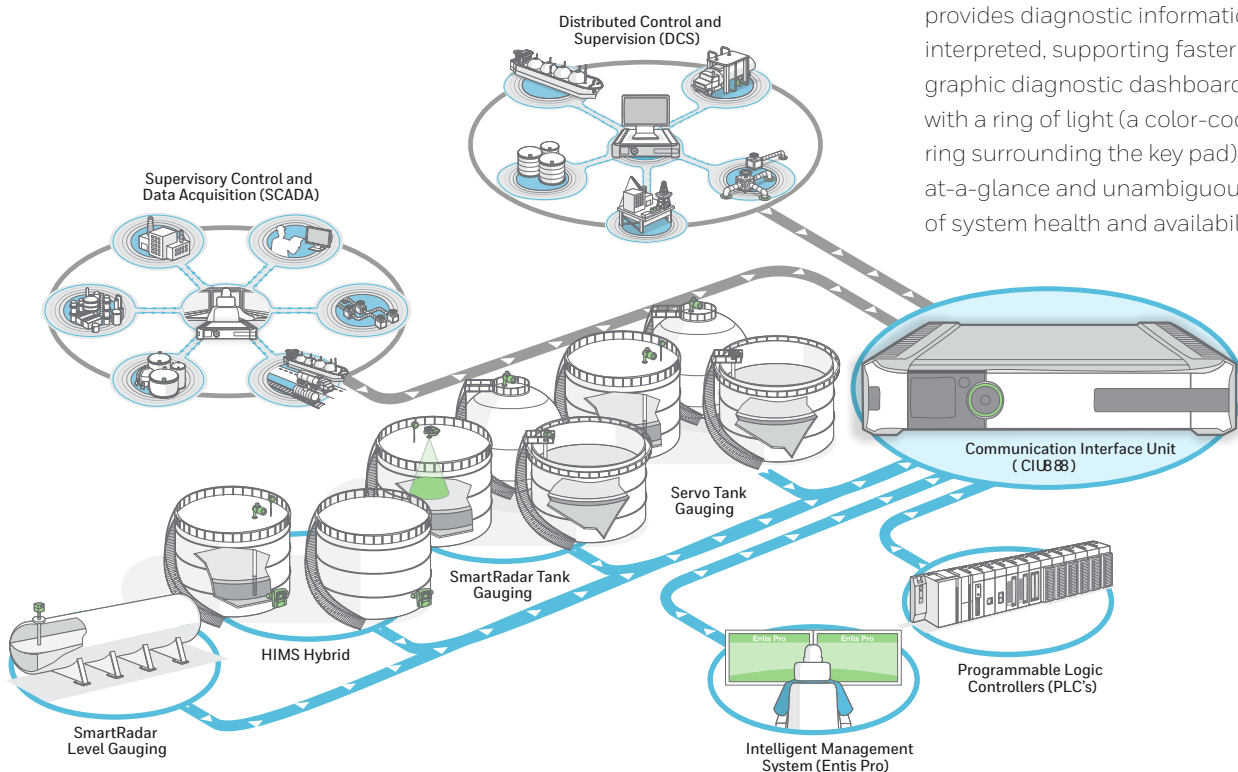

Front view (with closed door)

- LCD color display for status and diagnostics
- Convenient lid automatically covers access to Service- and USB-port and keys for Configuration lock and W&M sealing
- Navigation keys and ring of light showing CIU status

Rear view (left to right)

- Two serial host ports: Compatible with Entis Pro
- VGA & Audio (future use)
- Two USB ports: Auto-disabled (future use)
- 5 dedicated Ethernet ports, segregated by Firewall
- 6 flexible field and Host communication ports



OPC UA TCP and Modbus TCP/IP communication between the CIU 888 and the host systems is established through FTEA, FTEB and Office LAN ports. CIU 888 exposes the same data (Modbus maps) over the Ethernet host ports as that exposed in the serial host ports.

TECHNICAL SPECIFICATIONS—FUNCTIONAL (SOFTWARE)

GENERAL

Description	Field scanning and communication interface for tank inventory applications with optional embedded tank inventory calculation functionality.
Application	For all applications requiring accurate and reliable process and inventory data, such as refineries, tank farms and terminals. Data is suitable for custody transfer, safe product transfer and tank farm operation.
Intended Use	Control room equipment
Legal Metrology and Custody Transfer	Compliant to API-standards as stated by approval and certification by notified bodies as NMI.

FUNCTIONAL SPECIFICATION

Tank Database	80 tanks (one gauge per tank) 40 tanks (two gauges per tank)		
Redundancy	Hot standby, real-time synchronization (redundancy controlled by Entis Pro, ENTIS or modbus host)		
Supported Gauge Models	All GPU enabled tank gauges (such as 811, 813, 866, 854, 872, 873, 877, 894, 990, 954) & Emerson TRL/2		
Gauge Commands	<ul style="list-style-type: none"> • Lock test • Freeze • Alarm test (SmartRadar) 	<ul style="list-style-type: none"> • Unlock • Calibrate (854, 894) • Water dip 	<ul style="list-style-type: none"> • Block • Density dip • Density profile
Tank Scanning	6 field ports sequential and/or parallel, refresh rate 2-4 sec. ¹		
Inventory Calculations	Conform API MPMS Ch. 12.1		
Tank Capacity Tables (strapping tables)	Up to 5000 straps per tank, 400000 straps total		
Support API/ASTM Product Calculations	<ul style="list-style-type: none"> • ASTM D1250-80; conform Vol. X—Tables, 5, 6, 23, 24, 53, 54, 59, 60 and 59, 60 Commodities Product groups A, B, C & D • API MPMS Ch. 11.1 (2007; adj. to ASTM D1250-04 and IP-200)—Tables, 5, 6, 23, 24, 53, 54, 59, 60 and 59, 60; • Product groups A, B, C, D • API MPMS Ch. 11.2.4 (GPA TP-27)—Tables, 5, 6, 23, 24, 53, 54, 59, 60 and 59, 60; Product group E • ASTM D1250-52 – Tables 5, 6, 23 and 24 • ATSM D1250-53 – Tables 53 and 54 • ASTM D4311-83—Tables 1 and 2 • ASTM D4311-96—Table 1 • ASTM D4311-04—Tables 1 and 2 • ASTM D4311-15 • ASTM D4311M-15 • ASTM D-1555-16 – Tables 4 and alt. temperature • ASTM D-1555M-16 – Tables 4, 5 and alt. temperature • ASTM D1550-18 – Tables 1 and 2 		

Notes:

¹ Depending on number of used field ports, scan strategy, and baud rate.

(cont. next page)

FUNCTIONAL SPECIFICATION (CONT.)

Support Other Product Calculations	<ul style="list-style-type: none"> • Linear DCF • Linear TCF • Manual CTL • EN15940-19 (Hydrogenated Vegetable Oil) • SGS-21 (Ammonia) • NBR15639-16 (Ethanol / Alcohol) • User configurable density table • User configurable CTL table • User configurable concentration table • SGS-21 (Ammonia, Butadiene, Ethylene, Propylene) 	
Available Gauge Data ²	• Product level	• Gauge status and alarms
	• Product temperature	• Vapor temperature
	• Vapor pressure	• Ambient temperature
	• Water level	• Observed density (Servo, HTG, HIMS)
	• Temperature Profiles	• Density Profiles
	• Product pressure	• Floating roof levels
Available (Calculated) Inventory Data	• Volume (TOV, GOV, GSV, NSV)	• Mass (Liquid, vapor, total)
	• Reference density	• Volume correction factor (VCF, CTL)
	• S&W, Vapor (4 types)	• Volume derived flow
Clock & Time Synchronization	External using Entis Pro, ENTIS or Modbus host systems such as DCS	
Supported Engineering Units	Level	m, mm, ft, in, in/16 and ft-in-16 (fis)
	Temperature	°C, °F
	Density	kg/m ³ , °API, lb/ft ³ , RD60, lb/USgal
	Pressure	kgf/cm ² , kPa, psi(g), Pa
	Volume	m ³ , USgal, bbl, l(L)
	Mass/Weight	kg, lb, metric ton, long ton, US ton
	Flow	m ³ /min, m ³ /h, l/min, bbl/min, bbl/h, USgal/min, USgal/h, UKgal/h
Available Tank Correction Methods	<ul style="list-style-type: none"> • CTSh³ • Floating Roof Weight • Temperature GRH • Pressure GRH • Servo Wire correction • Floating Roof Immersion Compensation (RIC) • Floating Roof Adjustment (FRA) 	
Temperature and Density Profiles	<ul style="list-style-type: none"> • Temperature profiles - Periodic scanning of temperature profiles data from BPM (up to 16 points), TRL/2 (up to 14 points) and Modbus gauges (up to 16 points) and presentation in Modbus output (RTU and TCP/IP) and OPC UA TCP output based on configuration. • Density profiles - Density profiles data collection up to 50 density points from Honeywell Servo gauges and presentation in Modbus output and OPC UA TCP output based on user command. 	

HOST CONNECTIVITY

Serial Ports	2x modbus serial (+ 4 additional ports by using optional slots)
Supported Host Protocols	<ul style="list-style-type: none"> • Serial modbus (Slave) • CIU 858 emulation • CIU 880 Prime/Plus emulation (serial modbus)
Ethernet/LAN	3x Modbus TCP/IP and / or OPC UA TCP ethernet (FTEA, FTEB and Office LAN)

FIELD CONNECTIVITY

Field Ports	6x option slots (of which 4 ports can be used for serial host connectivity)
Wireless Connectivity	ISA 100 via Honeywell WDM
Available Option Boards	Enraf BPM fieldbus, Serial modbus (master) and Serial GPU input and TRL/2 Fieldbus

Notes:

²Depending on gauge functionality.

³Ambient temperature input required.

(cont. next page)

COMPLIANCE & CERTIFICATIONS (CONT.)

Electrical Safety	<ul style="list-style-type: none">• IEC 61010-1:2010 (3rd edition)• EN 61010-1:2010
European Directives	CE: <ul style="list-style-type: none">• 2006/95/EC (Low voltage directive)• 2004/108/EC (EMC)• CAN/CSA-C22.2 No. 61010-1-12• UL Std. No. 61010-1 (3rd Edition)
Self Monitoring & Diagnostics	Designed for compliance with NAMUR NE 107
Legal Metrology (Weight & Measures)	<ul style="list-style-type: none">• NMI – Netherlands

CIU 888 OPTION BOARD SPECIFICATIONS

ENRAF BPM FIELD BUS CARD (POS 8 TO 13 = B)

Physical Layer	2-wire Bi-phase mark modulated (MIL-STD-1553)
Supported Protocol(s)	Enraf BPM
Typical No. Field Devices	10-15, depending on cable spec and length
Baud Rate	1200/2400/4800 Baud
Distance	10 km or more depending on cable characteristics
Cable Characteristics	1 uF/200 Ohm max.
Type of Galvanic Isolation	Transformer coupled with ground shield
Galvanic Isolation	1500 V

TRL/2 FIELD BUS CARD

Physical layer	Emerson TRL/2 Protocol
Supported Protocol(s)	Modbus RTU
Typical No. Field Devices	8
Baud Rate	4800 Baud
Distance	4 km
Cable Characteristics	18 AWG (minimum) with shielded twisted pair, max 4 kms with max 8 multi drop Gauge connections
Type of Galvanic Isolation	Transformer coupled with ground shield
Galvanic Isolation	1500 V

ENRAF SERIAL COMMUNICATION CARD (GPU MASTER (INPUT), MODBUS MASTER (INPUT) AND MODBUS SLAVE (HOST))

Physical layer	2-4 wire RS-485 or RS-232C
Protocol(s)	<ul style="list-style-type: none">• GPU Master (Field communication)• Modbus Master (Field communication)• Modbus Slave (Host communication)
Baud Rate	1200 up to 38400 Baud
Type of Galvanic Isolation	Opto isolation
Galvanic Isolation	1500 V
Number of Modbus Slave Devices (for modbus master field communications)	<ul style="list-style-type: none">• 31 Modbus field devices (RS 485) multi-dropped• 1 Modbus field device (RS232)• 50 devices can be configured (If connected through a converter/concentrator)

TECHNICAL SPECIFICATIONS—HARDWARE

ELECTRICAL

Power Supply	100-240 Vac, auto ranging (-15% to +10%), 45-65 Hz
Power Rating	Max. 60 VA (35 VA nominal)
Nominal Start-Up Current	60 mA (Fuse: 2A Slow Blow); Start up current is (inrush): 60mA @230V
Over Voltage Category	II (EN60664-1 : 2007)
Cooling System	2 heat sinks with heat pipe design (no moving parts)
Battery	Type 3V, 225mAh (for back-up system clock only—10 yrs. estimated life time)

OPERATING SYSTEM

O/S	Linux Arch
Memory	4 GB Flash memory (upgradable)

USER INTERFACE AND I/O

Front Panel Display	Backlight LCD color display (50 x 38 mm; 320 x 240 pixels) for status and diagnostics
User Input	6 switches (←, →, ↑, ↓, OK and Esc) with LED (ring of light) status indication
Key Lock Switches	2x (for configuration, resp. W&M sealing)
Serial Ports	2x Opto isolation RS-232C
Ethernet Ports	5x 10/100 Mb on back side
Service Ethernet Port	1x behind front panel—DHCP enabled, auto sensing, 10/100 Mb

ENVIRONMENTAL

Ambient Temperature	0 °C to +60 °C (32 °F to 140 °F)
Storage Temperature	-20 °C to 85 °C (-4 °F to 185 °F)
Enclosure Classification	Against mechanical impact IP 30 (NEMA 1)
Humidity	0 to 90% non-condensing
EMC Class	CLASS A according to IEC61326 & OIML R85: 2008

MECHANICAL

Materials	<ul style="list-style-type: none"> • Enclosure: Acryl painted steel • Heat sinks (left and right side): Black anodized aluminum • Front panel: ABS/PPE
Dimensions (WxHxD)	400 x 93 x 283 mm (15¾ x 3¾ x 11¼ in.)
Weight	~ 7.5 kg (16.5 lb) (excluding option cards)
Installation	Wall mounting, 19" rack or table top (see Accessories)
Max. Load on Top (Table Top Use)	10 kg (22.0 lb)

AVAILABLE ACCESSORIES

19" installation bracket	Part no. A0888904			
Wall mounting bracket	Part no. A0888903			
Set Ethernet Cables	Part no. A0888911			
Set Ethernet cables	Part no. A0888911			
1 SYNC link			Orange	1 meter
2 FTE			Yellow/ Green	3 meter
1 LAN			Blue	2 meter
1 Remote Access			Red	3 meter
1 Service Port	Grey	3 meter		

Identification Code – Hardware Configuration

Pos 1 Application

- U** For Inventory Control of Bulk Storage Tanks
- X** Compliant with National Legal Metrology Requirements (specify country)

Pos 2 Base Configuration Hardware

- S** CIU for Tank Inventory Management

Pos 3 Memory

- A** 4 GB Flash

Pos 4 Selection

- H** CIU 888 Hardware Configuration

Pos 5, 6, 7 Product designation

- 8** Communication Interface Unit

Pos 8 Field Card Slot 1

- Z** Not Used
- M** Serial Modbus Input (Master)
- T** TRL/2 Fieldbus
- B** Enraf Fieldbus (BPM)
- G** Serial GPU (input)

Pos 9 Field Card Slot 2

- Z** Not Used
- M** Serial Modbus Input (Master)
- T** TRL/2 Fieldbus
- B** Enraf Fieldbus (BPM)
- G** Serial GPU (Input)

Pos 10 Field and Host Communication Slot 3

- Z** Not Used
- M** Serial Modbus Input (Master)
- T** TRL/2 Fieldbus
- H** Host Serial Modbus (Slave)
- B** Enraf Fieldbus (BPM)
- G** Serial GPU (Input)

Pos 11 Field and Host Communication Slot 4

- Z** Not Used
- M** Serial Modbus Input (Master)
- T** TRL/2 Fieldbus
- H** Host Serial Modbus (Slave)
- B** Enraf Fieldbus (BPM)
- G** Serial GPU (Input)

Pos 12 Field and Host Communication Slot 5

- Z** Not Used
- M** Serial Modbus Input (Master)
- T** TRL/2 Fieldbus
- H** Host Serial Modbus (Slave)
- C** Host CIU Emulation
- B** Enraf Fieldbus (BPM)
- G** Serial GPU (Input)

Pos 13 Field and Host Communication Slot 6

- Z** Not Used
- M** Serial Modbus Input (Master)
- T** TRL/2 Fieldbus
- H** Host Serial Modbus (Slave)
- B** Enraf Fieldbus (BPM)
- C** Host CIU Emulation
- G** Serial GPU (Input)

Pos 14 Extended Memory

- Z** Not Installed

Pos 15 Tag Plate

- Z** Not Required
- T** Tag Plate Sticker Added

Pos 16 Not Used

- Z** Not Used

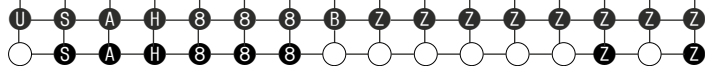

Typical Identification Code
Your Identification Code

Identification Code CIU 888 – Software Functionality 888

Pos 1 Application

- U** General purpose
- X** Legal Metrology Approved (NL)
- N** None (used in combination with Pos 20, in case Pos 1 doesn't need an upgrade)

Pos 2 Base Configuration Software

- S** Single CIU System
- R** Redundancy Enabled Per Unit
- N** None (used in combination with Pos 20, in case Pos 2 doesn't need an upgrade)

Pos 3 Functionality

- S** According Standard

Pos 4 CIU Type

- F** Tank Gauging Software Functionality

Pos 5, 6, 7 Product designation

- 8** **8** **8** Communication Interface Unit

Pos 8,9 Interfacing and Calculations

- S** **1** Scanning Functionality
- V** **1** Scanning with integrated Volume Calculation module
- N** **N** None (used in combination with Pos 20, in case Pos 8,9 doesn't need an upgrade)

Pos 10 Additional Inventory Calculations

- Z** Not enabled
- A** Ammonia, Butadiene, Ethylene, Propylene
- C** Chemicals Group 1 *²
- E** Ethanol/Alcohol
- H** Hydrogenated Vegetable Oil
- I** Ammonia, Chemicals Group 1, Ethanol/Alcohol, Hydrogenated Vegetable Oil Inventory Calculations

Pos 11 Host Communication OPCUA

- Z** No OPCUA-server
- S** Standard OPCUA server *³

Pos 12 Host Communication Modbus TCP/IP

- Z** Not Enabled
- S** Standard Ethernet (Modbus slave)

Pos 13 Host Communication Fault Tolerant Ethernet

- Z** Not Enabled

Pos 14 Floating Roof Immersion Compensation

- Z** Not Enabled
- F** Floating Roof Immersion Compensation Enabled

Pos 15 Temperature Profile

- Z** Not Enabled
- T** Temperature profile

Pos 16 Density Profile

- Z** Not Enabled
- D** Density profile

Pos. 17,18 Number of tanks

- | | | |
|----------|----------|-------------------|
| 0 | 5 | Tanks max. |
| 1 | 0 | Tanks max. |
| 2 | 0 | Tanks max. |
| 3 | 0 | Tanks max. |
| 4 | 0 | Tanks max. |
| 5 | 0 | Tanks max. |
| 6 | 0 | Tanks max. |
| 7 | 0 | Tanks max. |
| 8 | 0 | Tanks max. |

(cont. next page)

Notes:

² Butadiene (ASTM D-1550) Benzene, Cumene, Cyclohexane, Ethylbenzene, Styrene, Toluene, m-Xylene, o-Xylene, Aromatic Hydrocarbons (Temperature range – 148.9 – 204.4°C)
³ Standard OPCUA server option (S option in pos 11) is mandatory for ENTIS R130.1 or later versions

Identification Code CIU 888 – Software Functionality 888

U	5	S	F	8	8	8	V	1	S	Z	Z	Z	Z	Z	Z	0	5	Z	N
○	○	S	F	8	8	8	○	○	S	Z	Z	Z	Z	Z	Z	○	○	Z	N

U	0	Upgrade for 5 extra tanks (only if previous number of tanks was 5)
U	1	Upgrade for 10 extra tanks (till a maximum of 80 tanks / CIU) (Serial number and Licence required) only if Pos 20 = U
U	2	Upgrade for 20 extra tanks (till a maximum of 80 tanks / CIU) (Serial number and Licence required) only if Pos 20 = U
U	3	Upgrade for 30 extra tanks (till a maximum of 80 tanks / CIU) (Serial number and Licence required) only if Pos 20 = U
U	4	Upgrade for 40 extra tanks (till a maximum of 80 tanks / CIU) (Serial number and Licence required) only if Pos 20 = U
U	5	Upgrade for 50 extra tanks (till a maximum of 80 tanks / CIU) (Serial number and Licence required) only if Pos 20 = U
U	6	Upgrade for 60 extra tanks (till a maximum of 80 tanks / CIU) (Serial number and Licence required) only if Pos 20 = U
U	7	Upgrade for 70 extra tanks (till a maximum of 80 tanks / CIU) (Serial number and Licence required) only if Pos 20 = U
N	N	None (used in combination with Pos 20, in case Pos 17, 18 doesn't need an upgrade)

Pos 19 Language

Z English

Pos 20 Upgrade

N New CIU ordering

U Upgrade (Serial number of CIU and License required)

Typical Identification Code
Your Identification Code

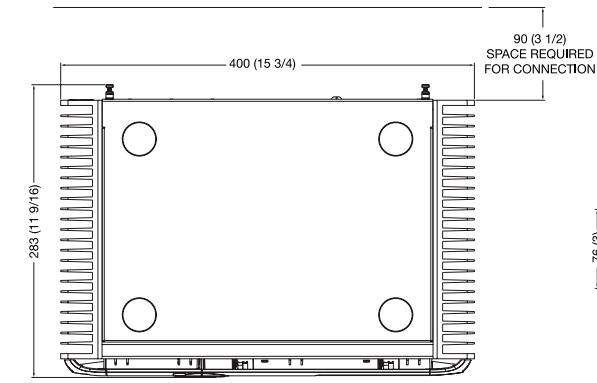

Top view

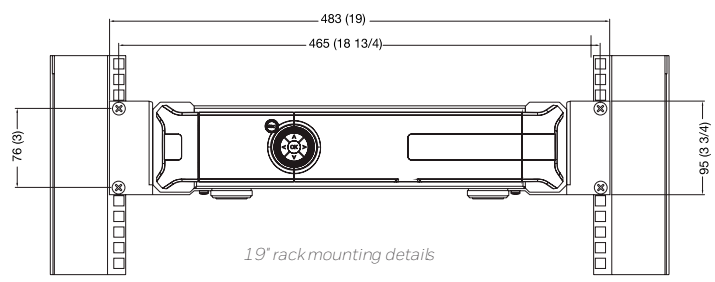

19' rack mounting details

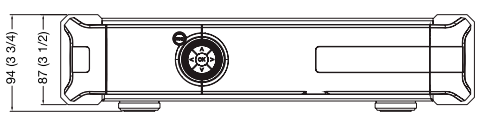

Front view

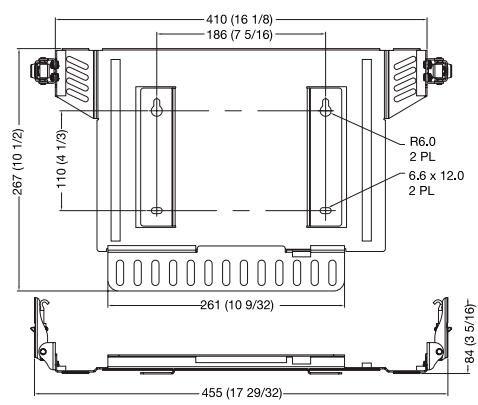

Wall mount bracket

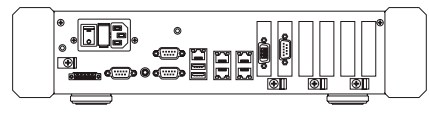

Rear view

Overall Dimensions

All dimensions in mm (In.)

For More Information

To learn more about Honeywell's Tank Gauging Solutions, visit process.honeywell.com or contact your Honeywell Account Manager.

Honeywell Process Solutions

2101 City West Blvd, Houston, TX 77042

Honeywell House, Skimped Hill Lane
Bracknell, Berkshire, England RG12 1EB UK

Building #1, 555 Huanke Road,
Zhangjiang Hi-Tech Industrial Park,
Pudong New Area, Shanghai 201203

process.honeywell.com

4718300 | 04/25
© 2025 Honeywell International Inc.

Honeywell